

FITTING INSTRUCTION

| Clamp mark in acc. with | | Cables joining |
|-------------------------|-----|---------------------------|
| ISO | PN | |
| 1 | L | Left directional lights |
| 2 | + | Rear fog lights |
| 3 | 31 | Ground |
| 4 | R | Right directional lights |
| 5 | 58R | Right side parking lights |
| 6 | 54 | Stoplights |
| 7 | 58L | Left side parking lights |

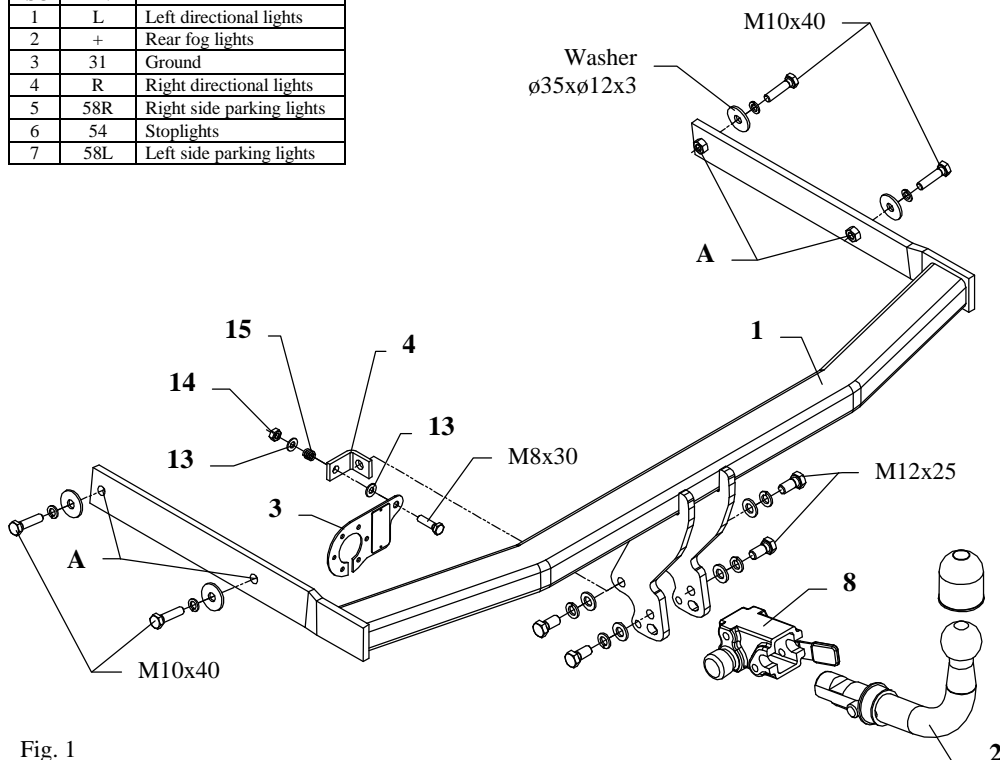

Fig. 1

This towbar is designed to assembly in following cars: **VOLKSWAGEN JETTA**, produced since 2005 and **VOLKSWAGEN GOLF V VARIANT (estate)** produced since 2007, catalogue no. **K49A** and is prepared to tow trailers max total weight **1700 kg** and max vertical mass **75 kg**.

From manufacturer

Thank you for buying our product. Their reliability has been confirmed in many tests. Reliability of towbar depends also on correct assembly and right operation. For this reasons we kindly ask to read carefully this instruction and apply to hints.

The towbar should be installing in points described by a car producer.

The instruction of the assembly

1. For the purpose of installing of the towbar one ought to disassemble the bumper and the metal reinforcement, which will not be assembled again.
2. Make cut outs (see fig. 2) in the bottom of the bumper. If you use moveable socket plate (see fig. 1) it is necessary to cut out major part of the bumper (you need to fit).

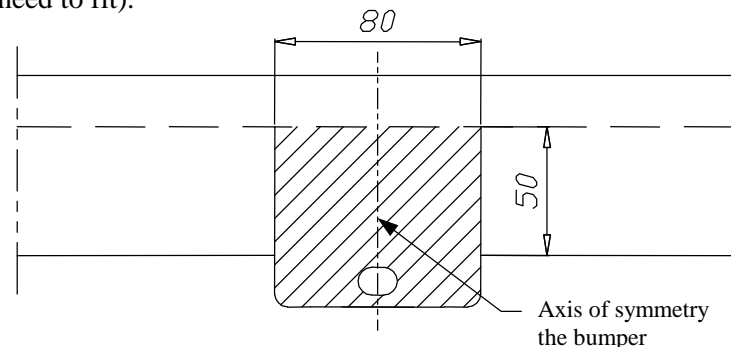

Fig. 2

3. Unscrew the thermal shield from above the muffler.
4. Slip the main bar of the towbar (pos. 1) into chassis members that way so holes with welded nuts (pos. A) be covered with factory-made assembly-holes and fix using bolts M10x40mm (pos. 6). Use washers (pos. 7).
5. Fix body of the automat (pos. 8) and the handle of socket plate (pos. 4) using bolts M12x25mm (pos. 5) and M12x30mm (pos. 18) from accessories. Place tow-ball (pos. 2) according to supplied instruction.
6. Fix the socket plate (pos. 3) as shown on the drawing.
7. Tighten all bolts according to the torque shown in the table.
8. Connect electric wires of 7-poles socket according to the instruction of the car. (Recommend to make at authorized service station).
9. Complete paint layer damaged during installation.

| | |
|---|----------------------|
| Torque settings for nuts and bolts (8,8): | |
| M 8 - 25 Nm | M 10 - 55 Nm |
| M 12 - 85 Nm | M 14 - 135 Nm |











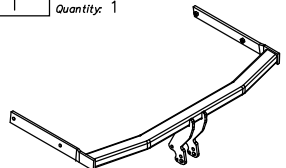



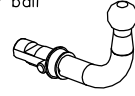
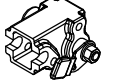

NOTE

After install the towbar you should get adequate note in registration book (at authorised service station).The car should be equipped with:

- Indicators
- Tow mirrors

Check all bolts and nuts after 1000km of exploitation. The ball of towbar must be always kept clear and conserve with a grease.

Towbar equipment:

| | | |
|--|---|---|
| Pos. 1 Name: Main bar Quantity: 1  | Pos. 6 Name: Bolt 8,8 B Quantity: 4 Dim.: M10x40mm  | Pos. 12 Name: Bolt 8,8 B Quantity: 1 Dim.: M8x30mm  |
| | Pos. 7 Name: Washer Quantity: 4 Dim.: Ø35xØ12x3mm  | Pos. 13 Name: Plain washer Quantity: 2 Dim.: Ø 8,5 mm  |
| Pos. 2 Name: Tow ball Quantity: 1  | Pos. 8 Name: Body of the automat Quantity: 1  | Pos. 14 Name: Nut 8 B Quantity: 1 Dim.: M8  |
| Pos. 3 Name: Socket plate Quantity: 1  | Pos. 9 Name: Plain washer Quantity: 4 Dim.: Ø 13 mm  | Pos. 15 Name: Spring Quantity: 1  |
| Pos. 4 Name: Handle of socket plate Quantity: 1  | Pos. 10 Name: Spring washer Quantity: 4 Dim.: Ø 12,2 mm  | Pos. 16 Name: Ball cover Quantity: 1  |
| Pos. 5 Name: Bolt 8,8 B Quantity: 3 Dim.: M12x25mm  | Pos. 11 Name: Spring washer Quantity: 4 Dim.: Ø 10,2 mm  | Pos. 17 Name: Body plug Quantity: 1  |
| | | Pos. 18 Name: Bolt 8,8 B Quantity: 1 Dim.: M12x30mm  |



PPUH AUTO-HAK S.J.

Produkcja Haków Holowniczych
Henryk & Zbigniew Nejman
76-200 SŁUPSK ul. Słoneczna 16K
tel/fax (059) 8-414-414; 8-414-413
E-mail: office@autohak.com.pl
www.autohak.com.pl

Towing hitch (without electrical set)

Class: **A50-X** Cat. no. **K49A**

Designed for:

Manufacturer: **VOLKSWAGEN**

Model: **JETTA**

produced since 2005 and

Model: **GOLF V Variant (estate)**

produced since 2007

Technical data:

D-value: 9,3 kN

maximum trailer weight: **1700 kg**

maximum vertical cup mass: **75 kg**

Approval number according to Directive 94/20/EC: **e20*94/20*0089*00**

Foreword

This towbar is designed according to rules of safety traffic regulations. The towing hitch is a safety component and can be install only by qualified personnel. Any alteration or conversion of the towing hitch is prohibited and would lead to cancellation of design certification. Remove insulating compound and underseal from vehicle (if present) in the area of the matting surfaces of the towing hitch.

The vehicle manufacturer's specifications regarding trailer load and max. vertical cup load are decisive for driving whereat values for the towing hitch cannot be exceeded.

D-value formula:

$$\frac{\text{Max trailer weight [kg]} \times \text{Max vehicle weight [kg]}}{\text{Max trailer weight [kg]} + \text{Max vehicle weight [kg]}} \times \frac{9,81}{1000} = D \text{ [kN]}$$