

## FITTING INSTRUCTION

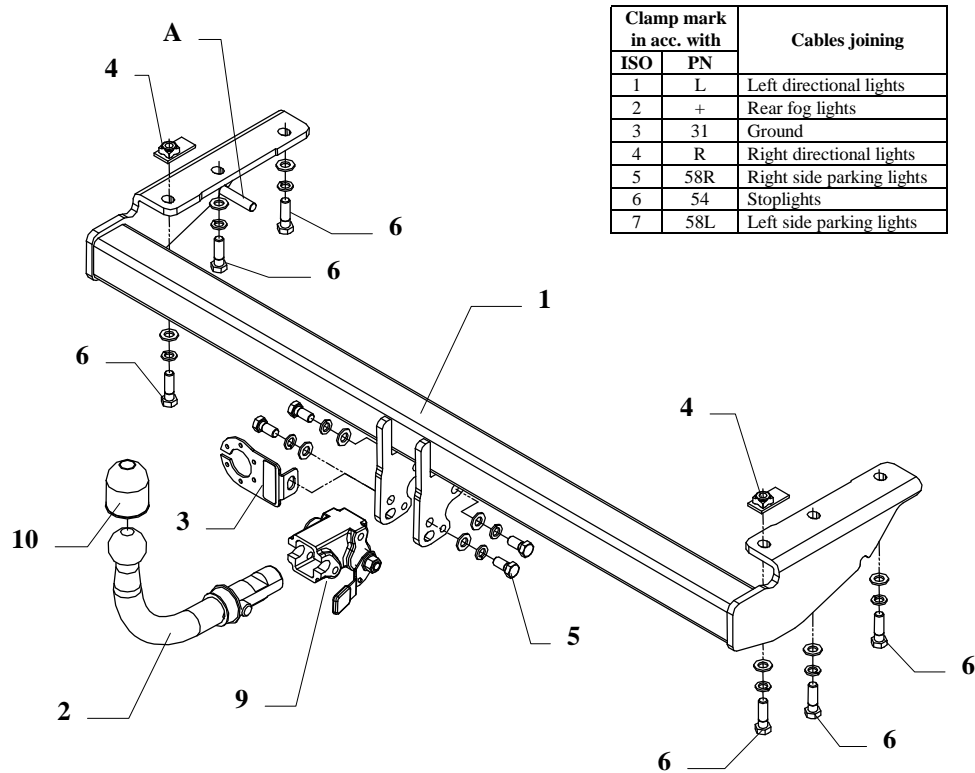

| Clamp mark in acc. with |     | Cables joining            |
|-------------------------|-----|---------------------------|
| ISO                     | PN  |                           |
| 1                       | L   | Left directional lights   |
| 2                       | +   | Rear fog lights           |
| 3                       | 31  | Ground                    |
| 4                       | R   | Right directional lights  |
| 5                       | 58R | Right side parking lights |
| 6                       | 54  | Stoplights                |
| 7                       | 58L | Left side parking lights  |

This towbar is designed to assembly in following cars: **VOLVO S80**, produced since 08.1998 till 07.2006, catalogue number **L17A** and is prepared to tow trailers max total weight **2000 kg** and max vertical load **75 kg**.

### *From manufacturer*

Thank you for buying our product. Their reliability has been confirmed in many tests. Reliability of towbar depends also on correct assembly and right operation. For this reasons we kindly ask to read carefully this instruction and apply to hints.

*The towbar should be install in points described by a car producer.*

## The instruction of the assembly

1. Disassemble the rear bumper (drill rivets).
2. Disassemble muffler handle – twist off two screws and drill pipe rivets from thermal shield.  
**NOTE!** Muffler handle will be not reinstall. Thermal shield fix by rivet again.
3. On the right side disassemble original towing eye (not used any more).
4. Put main bar of the towbar (pos. 1) to chassis members and fix it using bolts M12x40mm (pos. 6) through original holes in members. Elements (pos. 4) slide through holes in rear slice.
5. On handle of towbar pos. A put original muffler handle.
6. Assemble the bumper after cut out fragment according to figure 2.
7. Fix body of the automat (pos. 9) and the socket plate (pos. 3) using bolts M12x25mm (pos. 5) from accessories. Place tow-ball (pos. 2) according to supplied instruction.
8. Tighten all bolts according to the torque shown in the table.
9. Connect electric wires of 7-poles socket according to the instruction of the car. (Recommend to make at authorized service station)
10. Complete paint layer damaged during installation.

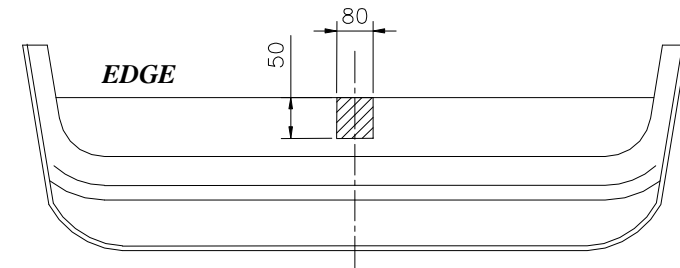

Fig. 2

Torque settings for nuts and bolts (8,8):

|            |       |            |        |
|------------|-------|------------|--------|
| <b>M8</b>  | 25 Nm | <b>M10</b> | 55 Nm  |
| <b>M12</b> | 85 Nm | <b>M14</b> | 135 Nm |







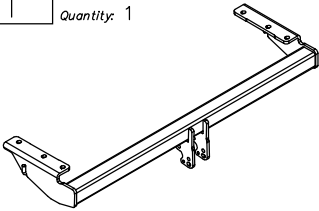

### **NOTE**

After install the towbar you should get adequate note in registration book (at authorised service station).The car should be equipped with:

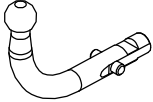
- Indicators
- Tow mirrors

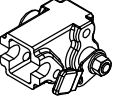
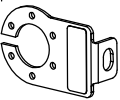
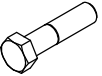
After 1000km check all bolts and nuts. The ball of towbar must be always kept clear and conserve with a grease.

## Towbar accessories:

|   |   |  |   |  |  |
|---|---|--|---|--|--|
| Pos.<br>1   | Name: Main bar<br>Quantity: 1                                   | Pos.<br>4  | Name: Jib with nut<br>Quantity: 2                 | Pos.<br>8  | Name: Spring washer<br>Quantity: 10<br>Dim.: $\varnothing$ 12,2 mm |
|   |   |   |   |  |  |
| Pos.<br>2   | Name: Tow ball<br>Quantity: 1                                   | Pos.<br>5  | Name: Bolt 8,8 B<br>Quantity: 4<br>Dim.: M12x25mm | Pos.<br>9  | Name: Body of the automat<br>Quantity: 1                           |
|  |   |   |   |  |  |
| Pos.<br>3   | Name: Socket plate<br>Quantity: 1                               | Pos.<br>6  | Name: Bolt 8,8 B<br>Quantity: 6<br>Dim.: M12x40mm | Pos.<br>10   | Name: Ball cover<br>Quantity: 1                                    |
|  |   |   |   |  |  |
| Pos.<br>7   | Name: Plain washer<br>Quantity: 10<br>Dim.: $\varnothing$ 13 mm | Pos.<br>11   | Name: Body plug<br>Quantity: 1                    |  |  |
|  |   |  |   |  |  |

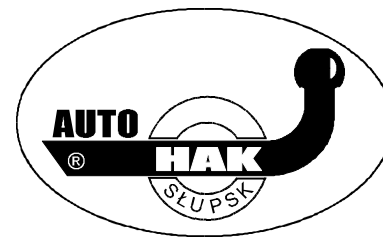

**PPUH AUTO-HAK S.J.**

Produkcja Haków Holowniczych  
Henryk & Zbigniew Nejman  
76-200 SŁUPSK ul. Słoneczna 16K  
tel/fax (059) 8-414-414; 8-414-413  
e-mail: [office@autohak.com.pl](mailto:office@autohak.com.pl)  
[www.autohak.com.pl](http://www.autohak.com.pl)

## Towing hitch (without electrical set)

Class: **A50-X** Cat. no. **L17A**

Designed for:

Manufacturer: **VOLVO**

Model: **S80**

produced since 08.1998 till 07.2006

Technical data:

**D-value: 10,3 kN**

maximum trailer weight: **2000 kg**

maximum vertical cup load: **75 kg**

**Approval number acc. to regulations EKG/ONZ 55.01: E20 55R-01 1605**

### *Foreword*

This towbar is designed according to rules of safety traffic regulations. The towing hitch is a safety component and must be installed only by qualified personnel. Any alteration or conversion to the towinh hitch is prohibited and would lead to cancellation of design certification. Remove insulating compound and underseal from vehicle (if present) in the area of the matting surfaces of the towing hitch.

The vehicle manufacturer's specifications regarding trailer load and max. vertical cup load are decisive for driving, and values for the towing hitch must not be exceeded.

*D-value formula:*

$$\frac{\text{Max trailer weight [kg]} \times \text{Max vehicle weight [kg]}}{\text{Max trailer weight [kg]} + \text{Max vehicle weight [kg]}} \times \frac{9,81}{1000} = D \text{ [kN]}$$