

## FITTING INSTRUCTION

Clamp mark in acc. with		Cables joining
ISO	PN	
1	L	Left directional lights
2	+	Rear fog lights
3	31	Ground
4	R	Right directional lights
5	58R	Right side parking lights
6	54	Stoplights
7	58L	Left side parking lights

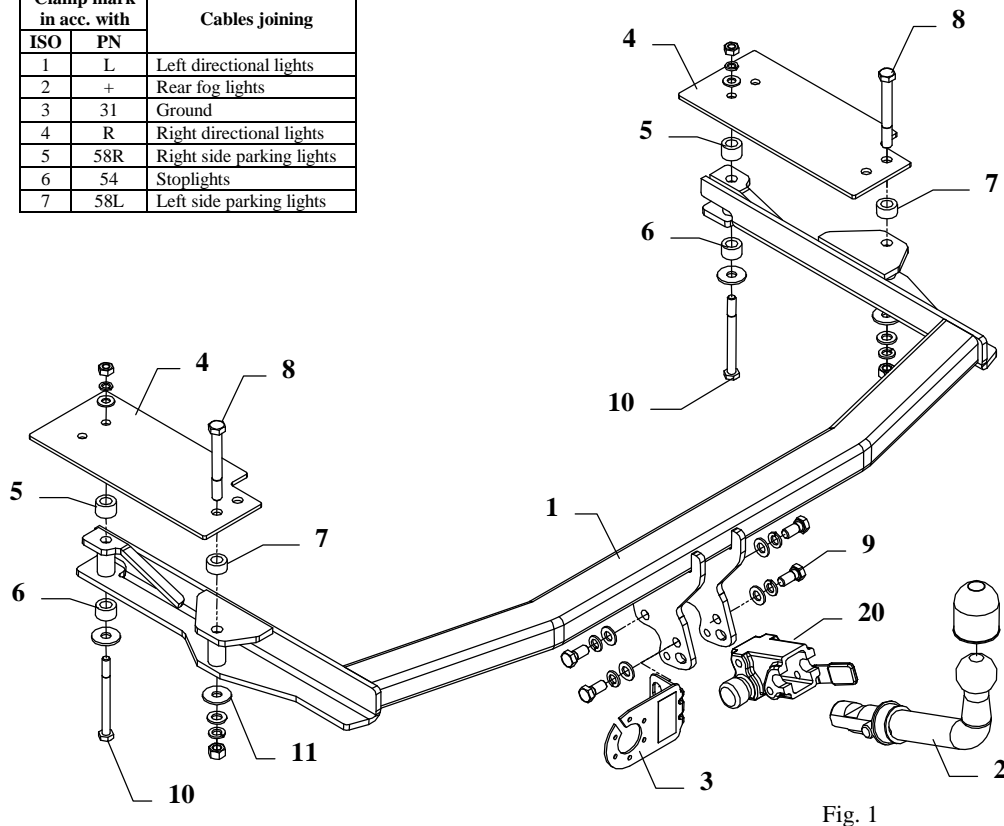

Fig. 1

This towbar is designed to assembly in following cars: **MAZDA 6 ESTATE (GY)**, produced since 01.2003 till 01.2008, catalogue number **M48A** and is prepared to tow trailers max total weight **1600 kg** and max vertical load **75 kg**.

### *From manufacturer*

Thank you for buying our product. Their reliability has been confirmed in many tests. Reliability of towbar depends also on correct assembly and right operation. For this reasons we kindly ask to read carefully this instruction and apply to hints.

*The towbar should be install in points described by a car producer.*

## The instruction of the assembly

1. Disassemble the bumper and metal reinforcement. From the rear handler get lower the muffler and rivet out the thermal shield.
2. In back wall make holes 85x60mm to make way to the chassis members (use template right and left).
3. Factory made holes in members 1, 2, 3 boring with drill  $\varnothing 25\text{mm}$  as shown on the fig. 3.
4. Put main bar of the towbar (pos. 1) in chassis members according to the holes in both elements.
5. In drilled holes  $\varnothing 25\text{mm}$  put sleeves as shown on the fig. 1.
6. Place fish-plates (pos. 4) and screw it as shown at the fig. 1.
7. After cuts out fragments of bumper (see fig. 2), assemble the bumper and thermal shield.

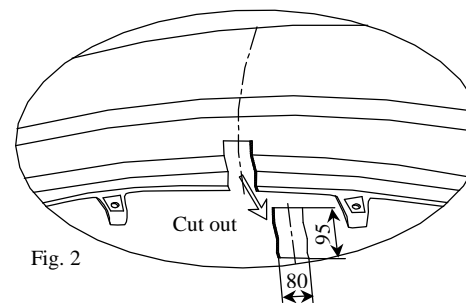

Fig. 2

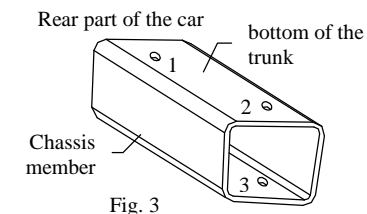

Fig. 3

8. Fix body of the automat (pos. 20) and the socket plate (pos. 3) using bolts M12x25mm (pos. 9) from accessories. Place tow-ball (pos. 2) according to supplied instruction.
9. Tighten all screw according to the torque shown in the table.
10. Connect the electric wires according to the instructions of the car. (Recommended to make at service station).
11. Complete the paint coating damaged during installation.

Torque settings for nuts and bolts (8,8):

<b>M6</b> - 11 Nm	<b>M8</b> - 25 Nm	<b>M10</b> - 50 Nm
<b>M12</b> - 87 Nm	<b>M14</b> - 138 Nm	<b>M16</b> - 210 Nm











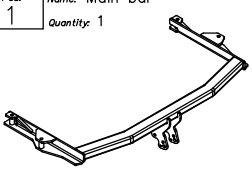

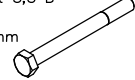

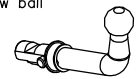

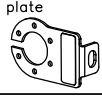

### NOTE

After install the towbar you should get adequate note in registration book (at authorised service station).The car should be equipped with:

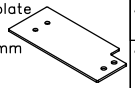
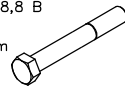
- Indicators
- Tow mirrors

After 1000 km of exploitation check all bolts and nuts. The ball of towbar must be always kept clear and conserve with a grease.

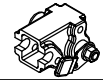
## Towbar accessories:

Pos. 1 Name: Main bar Quantity: 1 	Pos. 5 Name: Distance sleeve Quantity: 2 Dim.: Ø25, L=17mm 	Pos. 10 Name: Bolt 8,8 B Quantity: 2 Dim.: M10x110mm 	Pos. 16 Name: Spring washer Quantity: 6 Dim.: Ø 12,2 mm 
Pos. 2 Name: Tow ball Quantity: 1 	Pos. 6 Name: Distance sleeve Quantity: 2 Dim.: Ø25, L=15mm 	Pos. 11 Name: Washer Quantity: 4 Dim.: Ø35xØ12x3mm 	Pos. 17 Name: Spring washer Quantity: 2 Dim.: Ø 10,2 mm 
Pos. 3 Name: Socket plate Quantity: 1 	Pos. 7 Name: Distance sleeve Quantity: 2 Dim.: Ø25, L=13mm 	Pos. 12 Name: Nut 8 B Quantity: 2 Dim.: M12 	Pos. 18 Name: Rivet Quantity: 4 Dim.: 5x10mm 
Pos. 4 Name: Fish-plate Quantity: 2 Dim.: 298x130x5mm 	Pos. 8 Name: Bolt 8,8 B Quantity: 2 Dim.: M12x100mm 	Pos. 13 Name: Nut 8 B Quantity: 2 Dim.: M10 	Pos. 19 Name: Ball cover Quantity: 1 
	Pos. 9 Name: Bolt 8,8 B Quantity: 4 Dim.: M12x25mm 	Pos. 14 Name: Plain washer Quantity: 6 Dim.: Ø 13 mm 	Pos. 20 Name: Body of the automat Quantity: 1 
		Pos. 15 Name: Plain washer Quantity: 2 Dim.: Ø 10,5 mm 	Pos. 21 Name: Body plug Quantity: 1 



**PPUH AUTO-HAK S.J.**

Produkcja Zaczepów Kulowych  
Henryk & Zbigniew Nejman  
76-200 SŁUPSK ul. Słoneczna 16K  
tel/fax (059) 8-414-414; 8-414-413  
E-mail: [office@autohak.com.pl](mailto:office@autohak.com.pl)  
[www.autohak.com.pl](http://www.autohak.com.pl)

## Towing hitch (without electrical set)

Class: **A50-X** Cat. no. **M48A**

Designed for:

Manufacturer: **MAZDA**

Model: **6 (GY)**

Type: **ESTATE**

produced since 01.2003 till 01.2008

Technical data:

**D-value: 8,7 kN**

maximum trailer weight: **1600 kg**

maximum vertical cup load: **75 kg**

**Approval number according to Directive 94/20/EC:**

## Foreword

This towbar is designed according to rules of safety traffic regulations. The towing hitch is a safety component and can be install only by qualified personnel. Any alteration or conversion of the towing hitch is prohibited and would lead to cancellation of design certification. Remove insulating compound and underseal from vehicle (if present) in the area of the matting surfaces of the towing hitch.

The vehicle manufacturer's specifications regarding trailer load and max. vertical cup load are decisive for driving, and values for the towing hitch cannot be exceeded.

*D-value formula:*

$$\frac{\text{Max trailer weight [kg]} \times \text{Max vehicle weight [kg]}}{\text{Max trailer weight [kg]} + \text{Max vehicle weight [kg]}} \times \frac{9,81}{1000} = D \text{ [kN]}$$