

A-A

PL

Należy zagwarantować przestrzeń swobodną według załącznika VII, ilustracja 30 wytycznej 94/20/WE przy dopuszczalnym ciężarze całkowitym pojazdu.

GB

The clearance specified in appendix VII, diagram 30 of guideline 94/20/EC must be guaranteed (at laden weight of the vehicle).

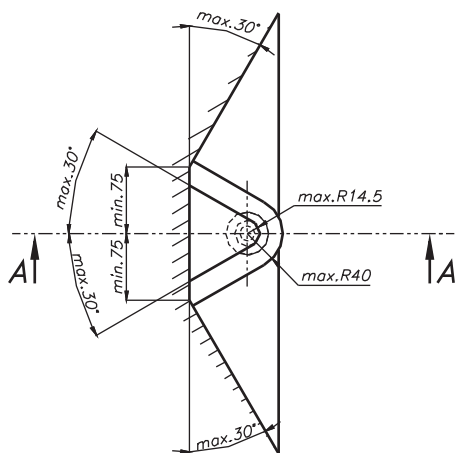

B-B

D

Der Freiraum nach Anhang VII, Abbildung 30 der Richtlinie 94/20/EG ist zu gewährleisten (bei zulässigem Gesamtgewicht des Fahrzeuges).



PPUH AUTO-HAK S.J.

Henryk & Zbigniew Nejman
76-200 SŁUPSK ul. Słoneczna 16K
tel/fax (059) 8-414-414; 8-414-413
E-mail: office@autohak.com.pl
www.autohak.com.pl



FIAT CROMA

D 9,1 kN

Typ: R47A

kg 1700

2005 →

kg ↓ 75

e20 e20*94/20*0742*00

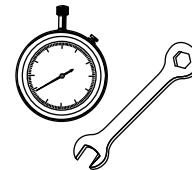

1,5h

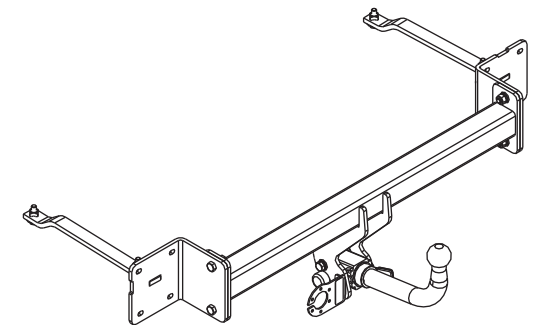

M6 - 11 Nm
M10 - 50 Nm
M14 - 138 Nm

M8 - 25 Nm
M12 - 87 Nm
M16 - 210 Nm



0 km → 1000 km

PL OD PRODUCENTA

Dziękujemy za wybór produkowanego przez naszą firmę zaczepu kulowego. Jego niezawodność została potwierdzona licznymi testami oraz opiniami zadowolonych klientów. Jednakże niezawodność zaczepów kulowych jest zależna również od prawidłowego montażu oraz prawidłowej eksploatacji. Z tego powodu prosimy Państwa o staranne przeczytanie niniejszej instrukcji montażu oraz przestrzeganie właściwych wskazówek.

Zaczep należy zamontować w miejscach do tego celu przeznaczonych przez producenta samochodu.

GB FROM MANUFACTURER

Thank you for buying our product. Their reliability has been confirmed in many tests. Reliability of towing hitch depends also on correct assembly and right operation. For this reasons we kindly ask to read carefully this instruction and apply to hints.

The towing hitch should be install in points described by a car producer.

D VON DEM HERSTELLER

Die Zuverlässigkeit der Anhängerkupplung ist jedoch auch von der ordnungsgemäßen Montage und der richtigen Nutzung abhängig. Daher werden Sie gebeten, sorgfältig die folgende Montageanleitung zu lesen und sich an die entsprechenden Anweisungen zu beachten.

Die Anhängerkupplung muss an den vom Fahrzeughersteller vorgeschriebenen Befestigungsstellen montiert werden.

PL

Zaczep kulowy jest skonstruowany zgodnie z zasadami bezpieczeństwa ruchu drogowego. Zaczep kulowy jest elementem wpływającym na bezpieczeństwo jazdy i może zostać zainstalowany wyłącznie przez personel wyspecjalizowany. Niedopuszczalne jest dokonywanie jakichkolwiek zmian w konstrukcji zaczepu. Powoduje to wygaśnięcie dopuszczenia do stosowania. W przypadku obecności masy izolacyjnej lub osłony podwozia w miejscu przylegania zaczepu, należy ją usunąć. Nieosłonięte miejsca karoserii oraz wywiercone otwory należy pomalować farbą antykorozyjną. Informacjami wiążącymi odnośnie wartości obciążeń są dane podawane przez producenta samochodu, względnie wartości maksymalnej masy przyczepy oraz maksymalnego nacisku na kulę, przy czym wartości parametrów zaczepu kulowego nie mogą być przekroczone.

Wzór do obliczania wartości siły D:

$$\frac{\text{Maks. masa przyczepy [kg]} \times \text{Maks. masa samochodu [kg]} \times \frac{9,81}{1000}}{\text{Maks. masa przyczepy [kg]} + \text{Maks. masa samochodu [kg]}} = D \text{ [kN]}$$

GB

This towing hitch is designed according to rules of safety traffic regulations. The towing hitch is a safety component and can be install only by qualified personnel. Any alteration or conversion of the towing hitch is prohibited and would lead to cancellation of design certification. Remove insulating compound and underseal from vehicle (if present) in the area of the matting surfaces of the towing hitch. The vehicle manufacturer's specifications regarding trailer load and max. vertical cup load are decisive for driving whereat values for the towing hitch cannot be exceeded.

D-value formula:

$$\frac{\text{Max trailer weight [kg]} \times \text{Max vehicle weight [kg]} \times \frac{9,81}{1000}}{\text{Max trailer weight [kg]} + \text{Max vehicle weight [kg]}} = D \text{ [kN]}$$

D

Die Anhängerkupplung erfüllt die Vorschriften der Verkehrssicherheit. Sie beeinflusst die Fahrsicherheit und daher ist ausschließlich nur vom Fachpersonal zu montieren. Es dürfen keinesfalls Konstruktionsänderungen vorgenommen werden. Sonst erlischt die Verwendungszulassung.

Falls es eine Isolationsschicht oder Fahrzeugunterbodenschutz gibt, wo die Anhängerkupplung befestigt wird, so sind diese zu entfernen. Andere Karosseriestellen und gebohrte Löcher sind mit der Antikorrosionsfarbe anzustreichen.



Für die Belastungswerte gelten die vom Fahrzeughersteller angegebenen Daten bzw. max. Masse der Anhänger und max. Stützlast. Dabei dürfen die Höchstkenwerte der Anhängerkupplung nicht überschritten werden.

D-Wert Formel:



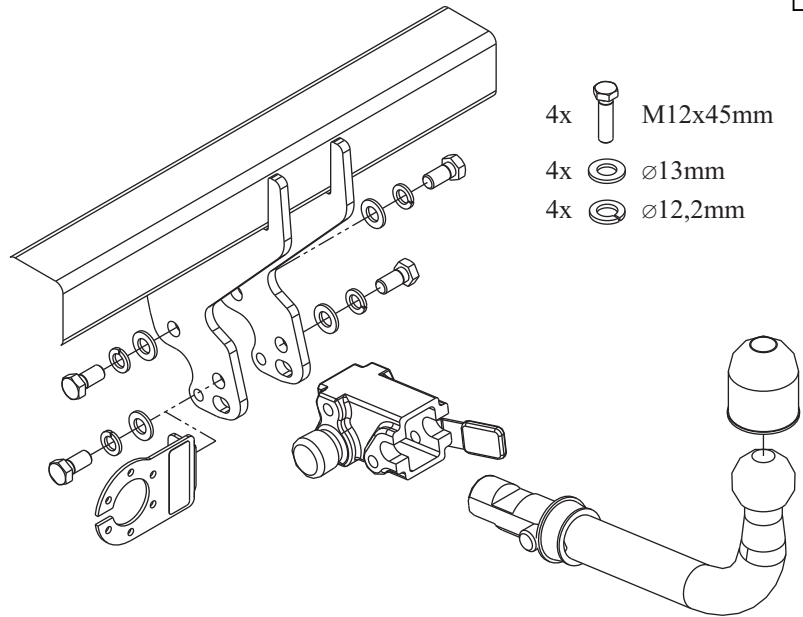





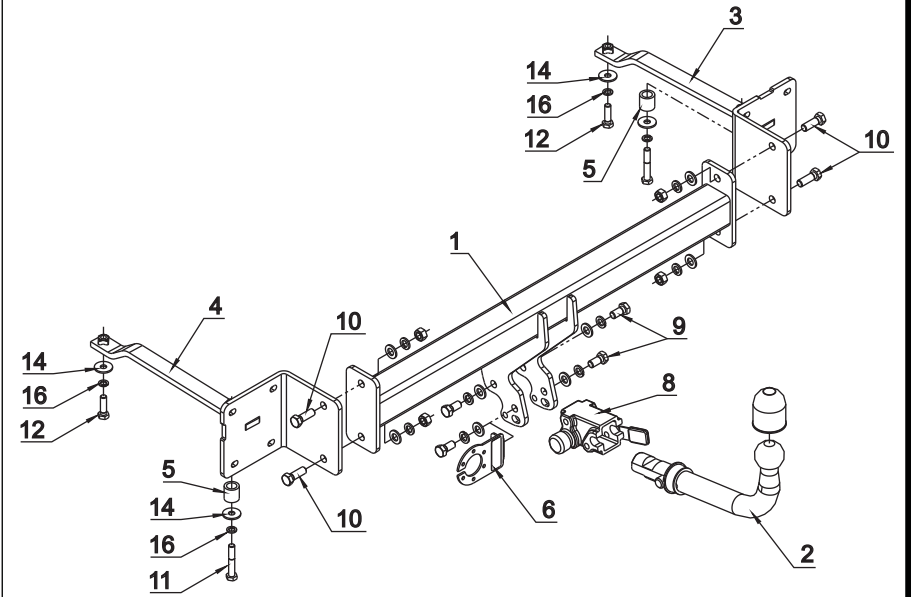

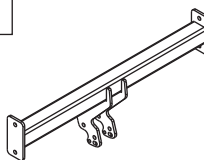

$$\frac{\text{max. Masse Anhänger [kg]} \times \text{Max. Fahrzeugesamtgewicht [kg]} \times \frac{9,81}{1000}}{\text{max. Masse Anhänger [kg]} + \text{Max. Fahrzeugesamtgewicht [kg]}} = D \text{ [kN]}$$

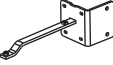
19

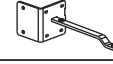

- 4x  M12x45mm
- 4x  Ø13mm
- 4x  Ø12,2mm



	x1		9 M12x25	x4
			10 M12x35	x4
			11 M10x60	x2
			12 M10x35	x2
	x1		13 Ø 13	x8
			14 Ø 30xØ10.5x2.5 10 (DIN 9021)	x4
	x1		15 Ø 12.2	x8
			16 Ø 10.2	x4
	x1		17 M12	x4
	x2		18	
	x1			
	x1			
	x1			

01

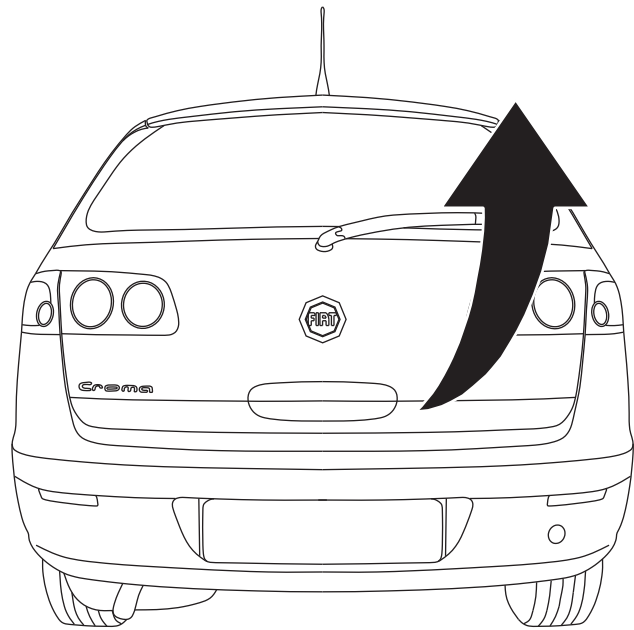

17

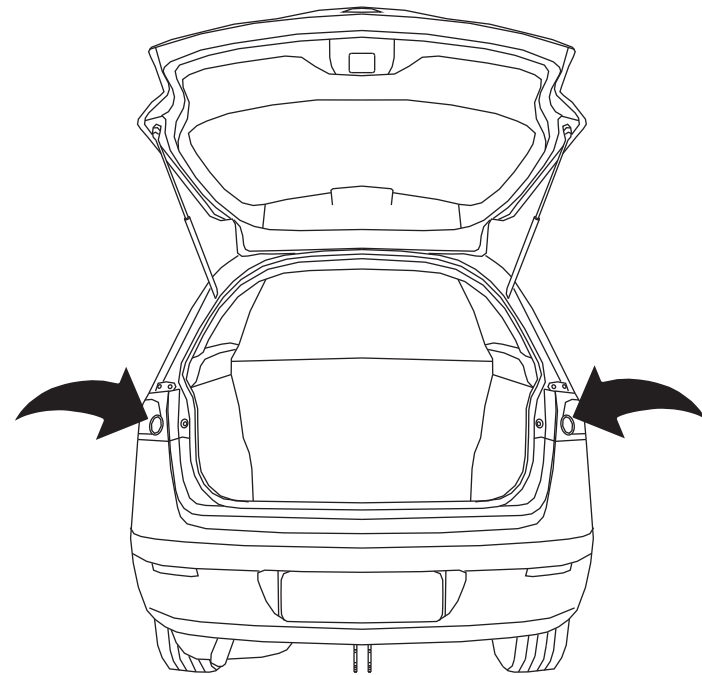

02

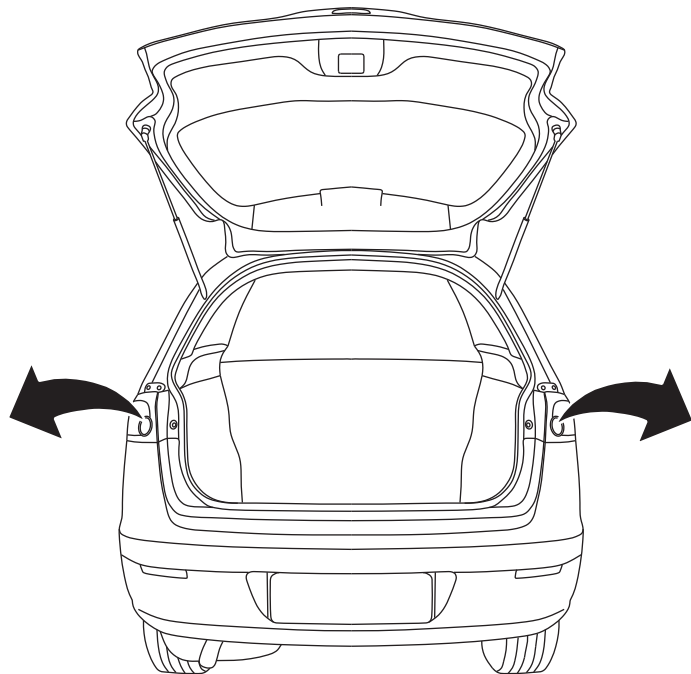

18

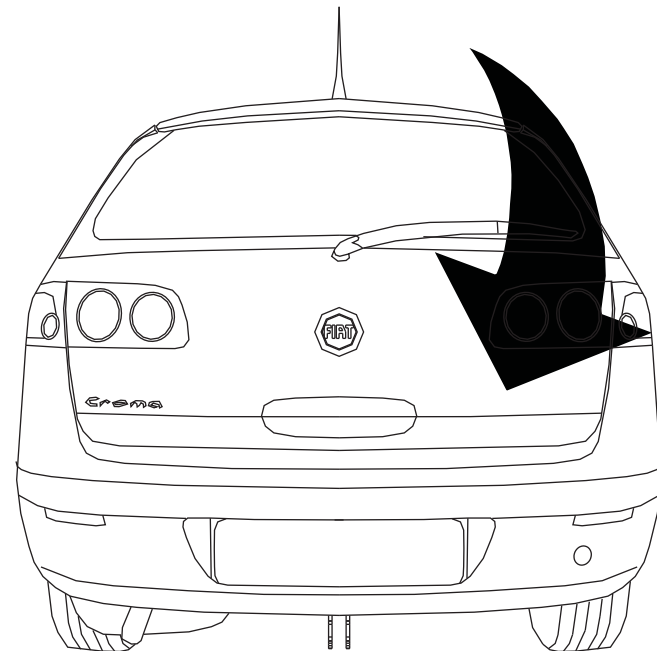

15

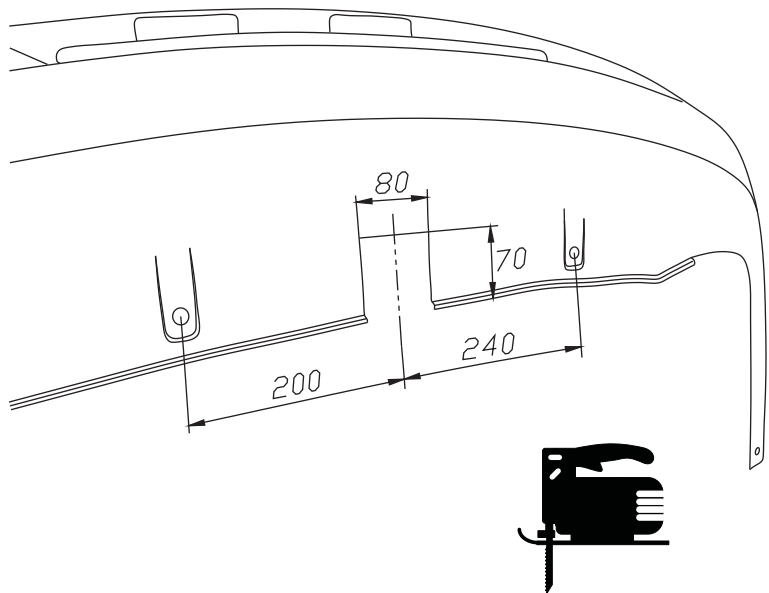

03



16

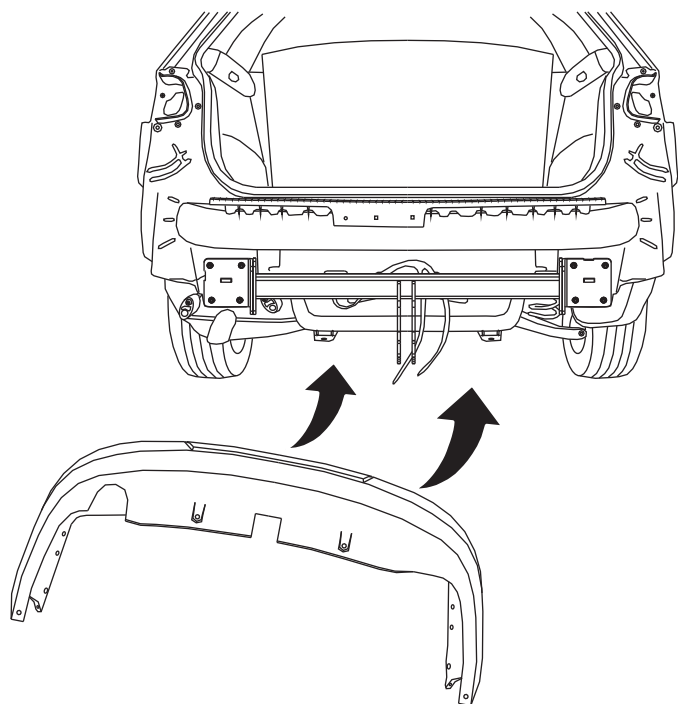

04

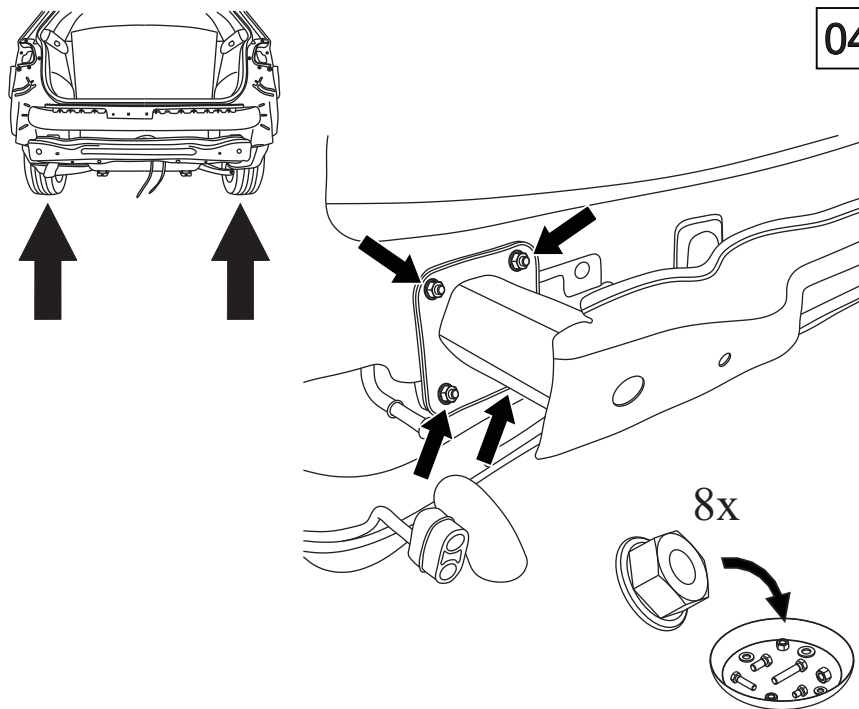



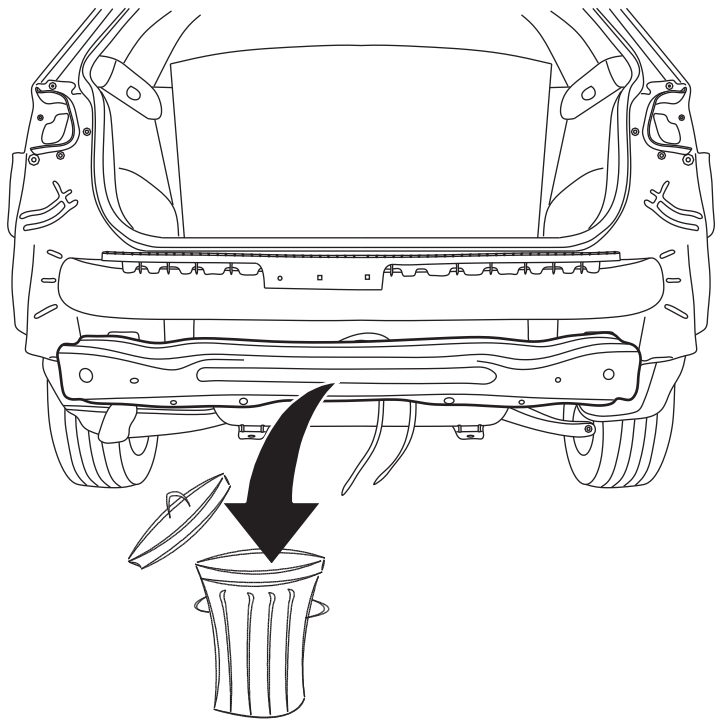

05

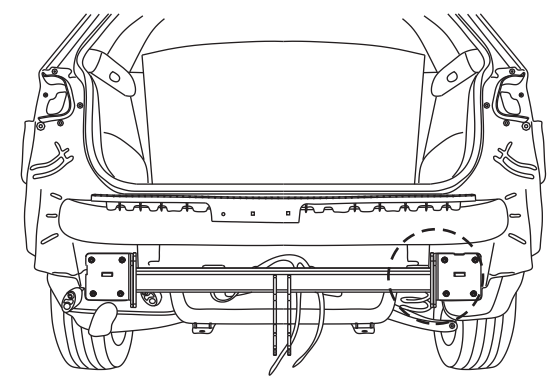

13



- 2x  M12x35mm
- 2x  Ø13mm
- 2x  Ø12,2mm
- 2x  M12

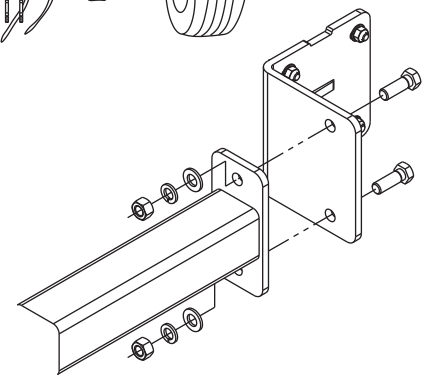

06

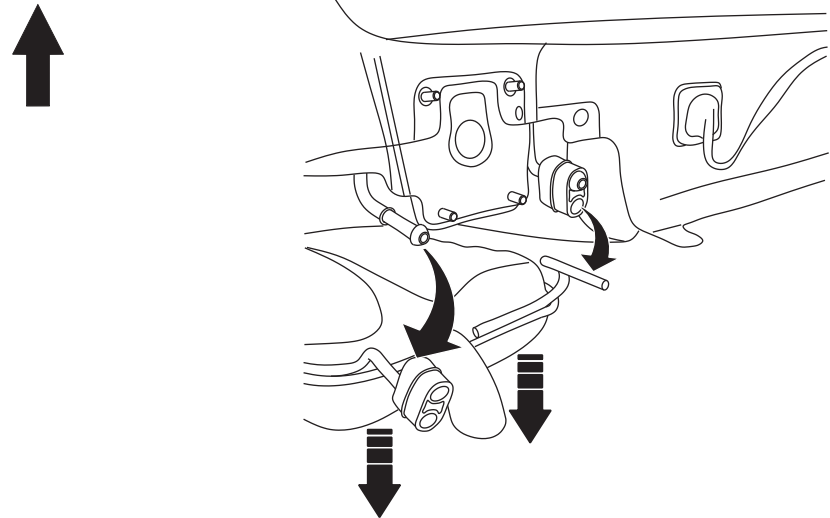
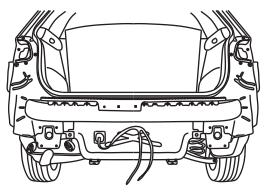

14

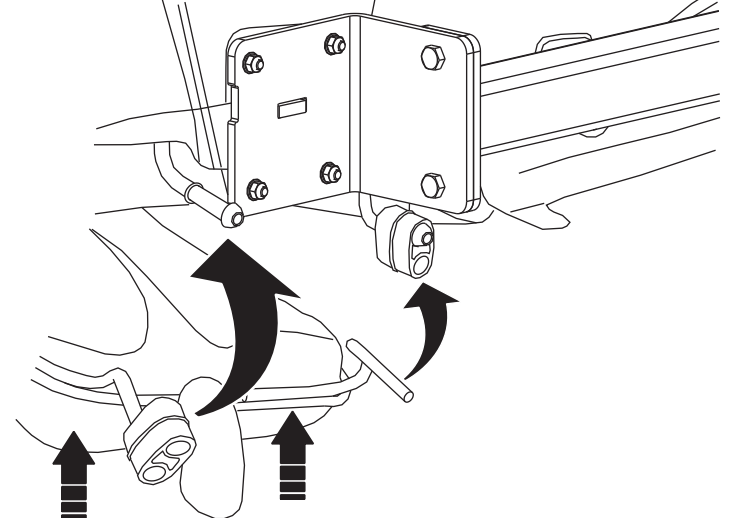
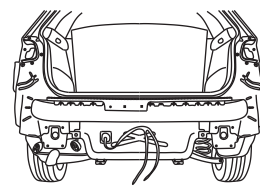



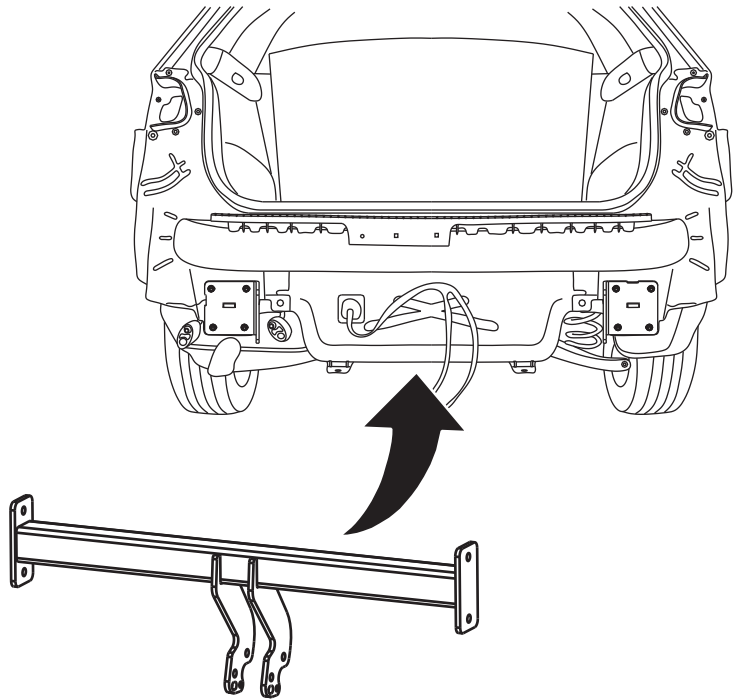

11

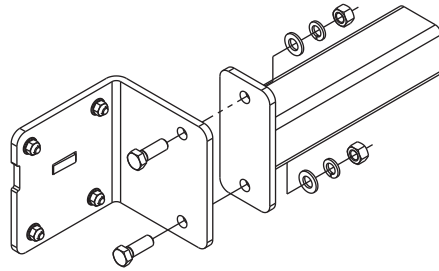
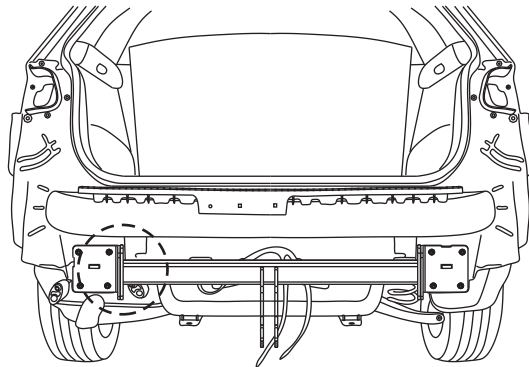



12

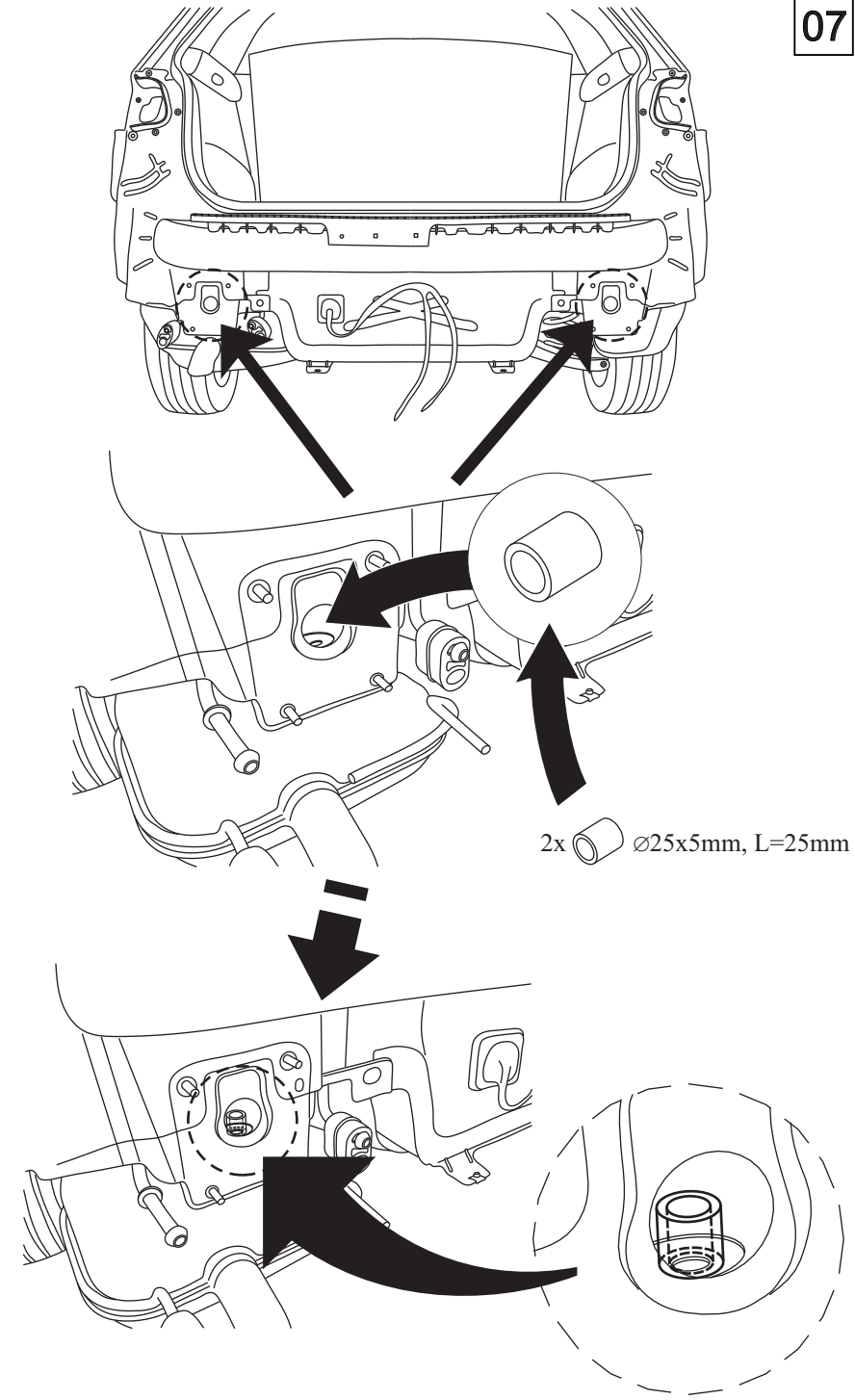

- 2x  M12x35mm
- 2x  $\varnothing 13\text{mm}$
- 2x  $\varnothing 12,2\text{mm}$
- 2x  M12

07



2x  $\varnothing 25 \times 5\text{mm}$, L=25mm

08

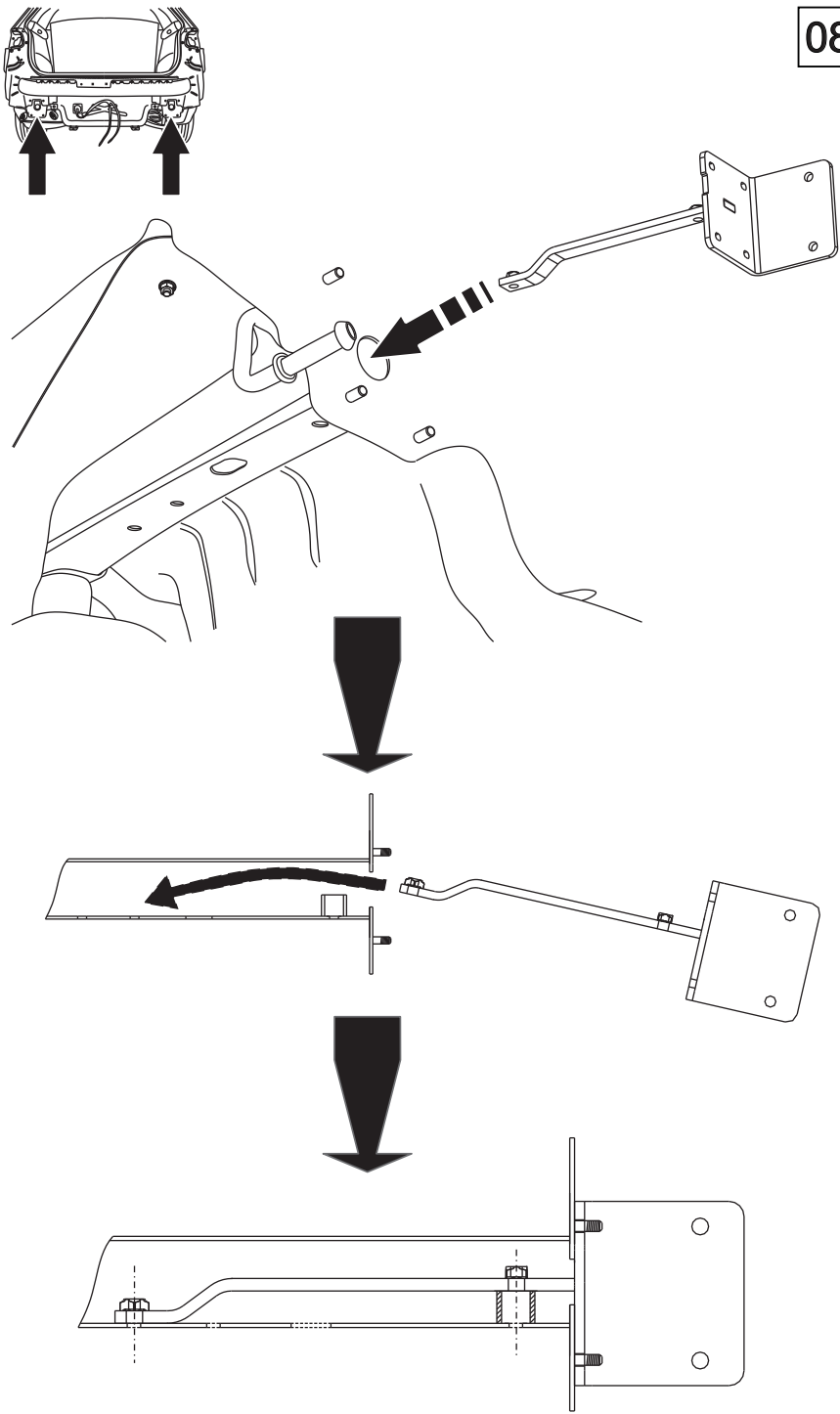

09

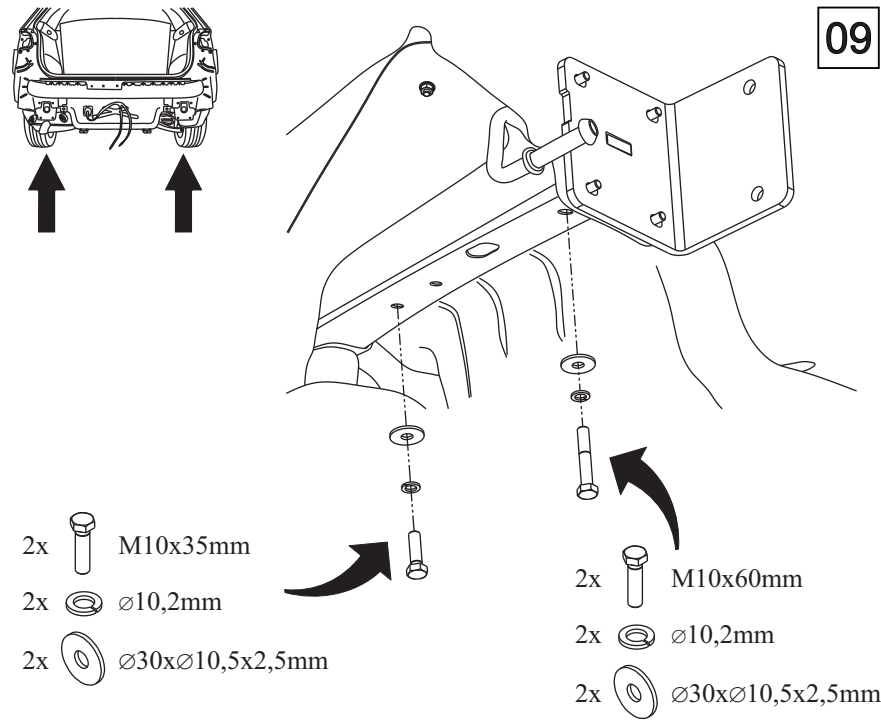

10

