

FITTING INSTRUCTION

Clamp mark in acc. with		Cables joining
ISO	PN	
1	L	Left directional lights
2	+	Rear fog lights
3	31	Ground
4	R	Right directional lights
5	58R	Right side parking lights
6	54	Stoplights
7	58L	Left side parking lights

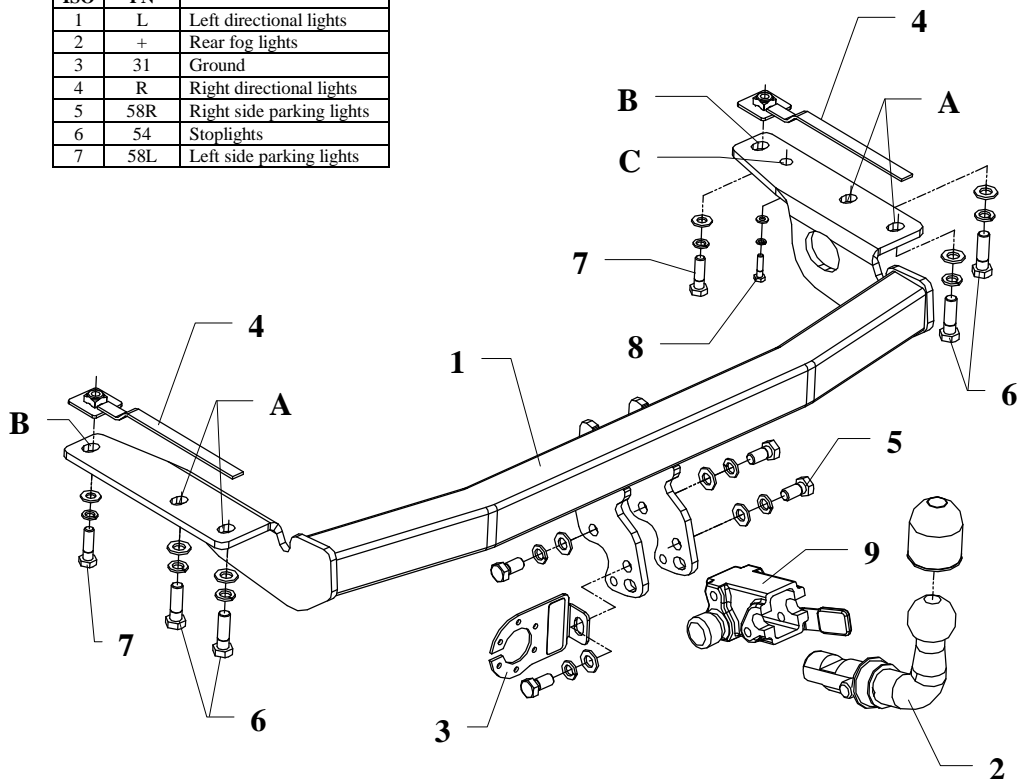

This towing hitch is designed to assembly in following cars: **TOYOTA COROLLA (E12), 3/5 door**, produced since 01.2002 till 2007, catalogue no. **O47A** and is prepared to tow trailers max total weight **1300 kg** and max vertical load **75 kg**.

From manufacturer

Thank you for buying our product. Their reliability has been confirmed in many tests. Reliability of towing hitch depends also on correct assembly and right operation. For this reasons we kindly ask to read carefully this instruction and apply to hints.

The towing hitch should be install in points described by a car producer.

The instruction of the assembly

1. Disassemble the rear bumper, original tow eye and metal support of bumper.
2. Disassemble the muffler and the thermal shield.
3. Put the main bar of the towing hitch (pos. 1) to the chassis member. Do it in such a way that holes (pos. A) cover original holes and fix it using M12x1,25x40mm (pos. 6).
- Attention!!!** The right side fit together with dismantled earlier tow eye.
4. Put nuts M10 (pos. 4) to the chassis members. Do it in such a way that they cover holes (pos. B) and fix it using bolts M10x35mm (pos. 7).
5. Fix the thermal shield using one original bolt and one bolt from the towing hitch accessories M6x25mm (pos. 8) which is fixed through hole (pos. C).
6. Reassemble the muffler and metal support of bumper.
7. Reassemble the bumper, earlier cutting it according to fig. 2.
8. Fix body of the automat (pos. 9) and the socket plate (pos. 3) using bolts M12x25mm (pos. 5) from accessories. Place tow-ball (pos. 2) according to supplied instruction.
9. Tighten all nuts and bolts according to the torque shown in the table.
10. Connect to the electric wires according to the instructions of the car.
11. Complete the paint cover of towing hitch (during the mounting paint cover could be destroyed).

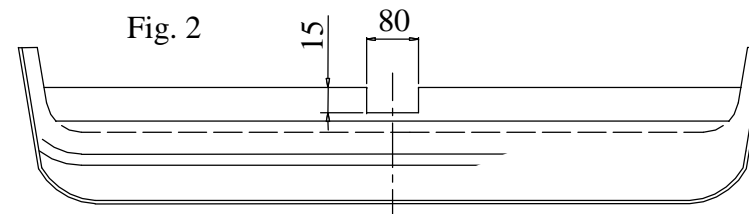

Torque settings for nuts and bolts (8,8):	
M 8 - 25 Nm	M 10 - 55 Nm
M 12 - 85 Nm	M 14 - 135 Nm











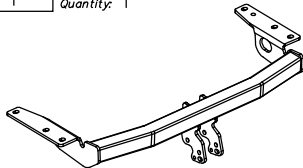
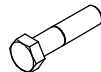

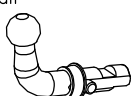

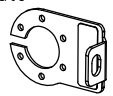
NOTE

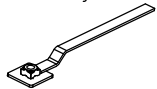
After install the towing hitch you should get adequate note in registration book (at authorised service station).The car should be equipped with:

- Indicators
- Tow mirrors

After 1000km of exploitation check all bolts and nuts. The ball of towing hitch must be always kept clear and conserve with a grease.

Towing hitch accessories:

Pos. 1 Name: Main bar Quantity: 1 	Pos. 6 Name: Bolt 8,8 B Quantity: 4 Dim.: M12x1,25x40mm 	Pos. 12 Name: Plain washer Quantity: 1 Dim.: Ø 6,5 mm 
Pos. 2 Name: Tow ball Quantity: 1 	Pos. 7 Name: Bolt 8,8 B Quantity: 2 Dim.: M10x35mm 	Pos. 13 Name: Spring washer Quantity: 8 Dim.: Ø 12,2 mm 
Pos. 3 Name: Socket plate Quantity: 1 	Pos. 8 Name: Bolt 8,8 B Quantity: 1 Dim.: M6x25mm 	Pos. 14 Name: Spring washer Quantity: 2 Dim.: Ø 10,2 mm 
Pos. 4 Name: Nut on the jib Quantity: 2 	Pos. 9 Name: Body of the automat Quantity: 1 	Pos. 15 Name: Spring washer Quantity: 1 Dim.: Ø 6,2 mm 
Pos. 5 Name: Bolt 8,8 B Quantity: 4 Dim.: M12x25mm 	Pos. 10 Name: Plain washer Quantity: 8 Dim.: Ø 13 mm 	Pos. 16 Name: Ball cover Quantity: 1 
	Pos. 11 Name: Plain washer Quantity: 2 Dim.: Ø 10,5 mm 	Pos. 17 Name: Body plug Quantity: 1 



PPUH AUTO-HAK S. J.

Produkcja Zaczepów Kulowych
Henryk & Zbigniew Nejman
76-200 SŁUPSK ul. Słoneczna 16K
tel/fax (059) 8-414-414; 8-414-413
E-mail: office@autohak.com.pl
www.autohak.com.pl

Towing hitch (without electrical set)

Class: **A50-X** Cat. no. **O47A**

Designed for:

Manufacturer: **TOYOTA**

Model: **COROLLA**

Type: **3/5 door (E12)**

produced since 01.2002 till 2007

Technical data:

D-value: 7,14 kN

maximum trailer weight: **1300 kg**

maximum vertical cup load: **75 kg**

Approval number acc. to regulations EKG/ONZ 55.01: **E20-55R-01 0696**

Foreword

This towing hitch is designed according to rules of safety traffic regulations. The towing hitch is a safety component and must be installed only by qualified personnel. Any alteration or conversion to the towing hitch is prohibited and would lead to cancellation of design certification. Remove insulating compound and underseal from vehicle (if present) in the area of the matting surfaces of the towing hitch.

The vehicle manufacturer's specifications regarding trailer load and max. vertical cup load are decisive for driving, and values for the towing hitch cannot be exceeded.

D-value formula:

$$\frac{\text{Max trailer weight [kg]} \times \text{Max vehicle weight [kg]}}{\text{Max trailer weight [kg]} + \text{Max vehicle weight [kg]}} \times \frac{9,81}{1000} = D \text{ [kN]}$$