

FITTING INSTRUCTION

Clamp mark in acc. with		Cables joining
ISO	PN	
1	L	Left directional lights
2	+	Rear fog lights
3	31	Ground
4	R	Right directional lights
5	58R	Right side parking lights
6	54	Stoplights
7	58L	Left side parking lights

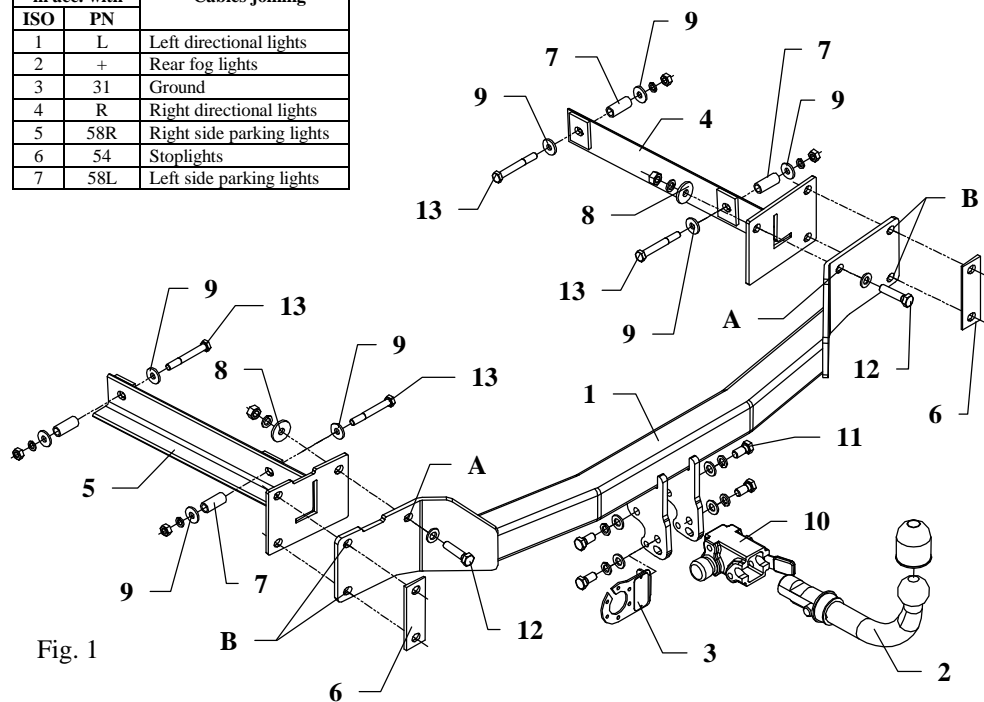

Fig. 1

This towing hitch is designed to assembly in following cars: **MERCEDES S-CLASS** produced since 1999 till 2002, catalogue no. **D36A** and is prepared to tow trailers max total weight **2100 kg** and max vertical load **85 kg**.

Torque settings for nuts and bolts (8,8):	
M 8 - 25 Nm	M 10 - 55 Nm
M 12 - 85 Nm	M 14 - 135 Nm

From manufacturer

Thank you for buying our product. Their reliability has been confirmed in many tests. Reliability of towing hitch depends also on correct assembly and right operation. For this reasons we kindly ask to read carefully this instruction and apply to hints.

The towing hitch should be install in points described by a car producer.

The instruction of the assembly

1. Remove the floor mat from the trunk and the side covering at the left and right.
2. Take out the battery and remove the CD-player. **Attention!** Do not leave the vehicle without power for more than 30 minutes! If the power is disconnected for more than 30 minutes, the system will need to be reset by the dealer of the car.
3. Disassemble the bumper together with its aluminium reinforcement. Remove the adjustment wedges at the left and right (will not be assembled again). Cut out fragments inside of the bumper in accordance with fig. 2 (left and right side).
4. Take the exhausts silencers out of the suspension rubbers at the left and right and take off the heat shield at both sides.
5. In the trunk (at the internal side of the chassis members) find blind holes and drill them trough ($\phi 13\text{mm}$) using a right-angle drill.
6. Slip side arms (pos. 4 and 5) to chassis members and fix them (in accordance with fig. 1) using bolts M10x80mm (pos. 13). Use distance sleeves (pos. 7) and large washers (pos. 9).
7. Apply the main bar of the towing hitch (pos. 1) to already installed side arms and fix it trough holes A using bolts M12x50mm (pos. 12). Use large washers (pos. 8).
8. Install fulfilment of the bumper and heat shields. Install the bumper in points B using original bolts and cut fish-plates (pos. 6).
9. Reassemble elements disassembled at points 1 and 2.
10. Fix body of the automat (pos. 10) and the socket plate (pos. 3) using bolts M12x25mm (pos. 11) from accessories. Place tow-ball (pos. 2) according to supplied instruction.
11. Tighten all bolts according to the torque shown in the table.
12. Connect electric wires of 7-poles socket according to the instruction of the car. (Recommend to make at authorized service station).
13. Complete paint layer damaged during installation.

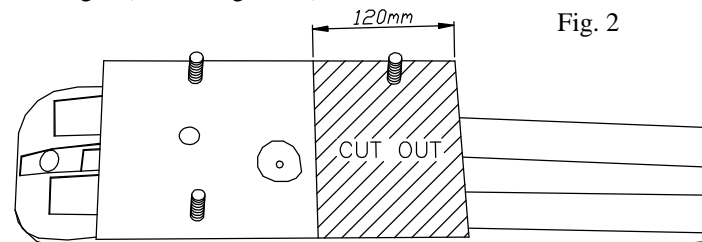

Fig. 2

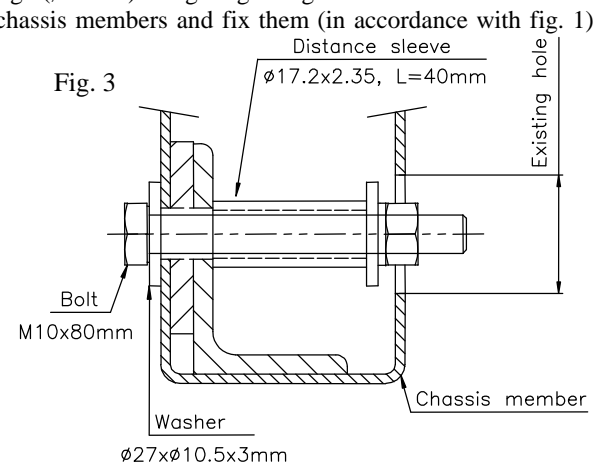

Fig. 3

NOTE

After install the towing hitch you should get adequate note in registration book (at authorised service station). The car should be equipped with:

- Indicators
- Tow mirrors

After 1000km check all bolts and nuts. The ball of towing hitch must be always kept clear and conserve with a grease.

Towing hitch accessories:

Pos. 1 Main bar PCS.: 1	Pos. 5 Left arm cpl. PCS.: 1	Pos. 10 Body of the automat PCS.: 1	Pos. 15 Nut 8 B M10 PCS.: 4
Pos. 2 Tow ball PCS.: 1	Pos. 6 Cut fish-plate PCS.: 2	Pos. 11 Bolt 8,8 B M12x25mm PCS.: 4	Pos. 16 Plain washer ø12mm PCS.: 6
Pos. 3 Socket plate PCS.: 1	Pos. 7 Distance sleeve ø17.2x2.35mm L=40mm PCS.: 4	Pos. 12 Bolt 8,8 B M12x50mm PCS.: 2	Pos. 17 Spring washer ø12mm PCS.: 4
Pos. 4 Right arm cpl. PCS.: 1	Pos. 8 Washer ø36xø12x4mm PCS.: 2	Pos. 13 Bolt 8,8 B M10x80mm PCS.: 4	Pos. 18 Spring washer ø10mm PCS.: 6
	Pos. 9 Washer ø27xø10.5x3mm PCS.: 8	Pos. 14 Nut 8 B M12 PCS.: 2	Pos. 19 Ball cover PCS.: 1
		Pos. 20 Body plug PCS.: 1	



PPUH AUTO-HAK S.J.

Produkcja Haków Holowniczych
Henryk & Zbigniew Nejman
76-200 SŁUPSK ul. Słoneczna 16K
tel/fax (059) 8-414-414; 8-414-413
E-mail: office@autohak.com.pl
www.autohak.com.pl

Towing hitch (without electrical set)

Class: **A50-X** Cat. no. **D36A**

Designed for:

Manufacturer: **MERCEDES**

Model: **S-CLASS**

produced since 1999 till 2002

Technical data:

D-value: 12,3 kN

maximum trailer weight: **2100 kg**

maximum vertical cup load: **85 kg**

Approval number according to Directive 94/20/EC: e20*94/20*0298*00

Foreword

This towing hitch is designed according to rules of safety traffic regulations. The towing hitch is a safety component and can be install only by qualified personnel. Any alteration or conversion of the towing hitch is prohibited and would lead to cancellation of design certification. Remove insulating compound and underseal from vehicle (if present) in the area of the matting surfaces of the towing hitch.

The vehicle manufacturer's specifications regarding trailer load and max. vertical cup load are decisive for driving whereat values for the towing hitch cannot be exceeded.

D-value formula:

$$\frac{\text{Max trailer weight [kg]} \times \text{Max vehicle weight [kg]}}{\text{Max trailer weight [kg]} + \text{Max vehicle weight [kg]}} \times \frac{9,81}{1000} = D \text{ [kN]}$$