

FITTING INSTRUCTION

Clamp mark in acc. with		Cables joining
ISO	PN	
1	L	Left directional lights
2	+	Rear fog lights
3	31	Ground
4	R	Right directional lights
5	58R	Right side parking lights
6	54	Stoplights
7	58L	Left side parking lights

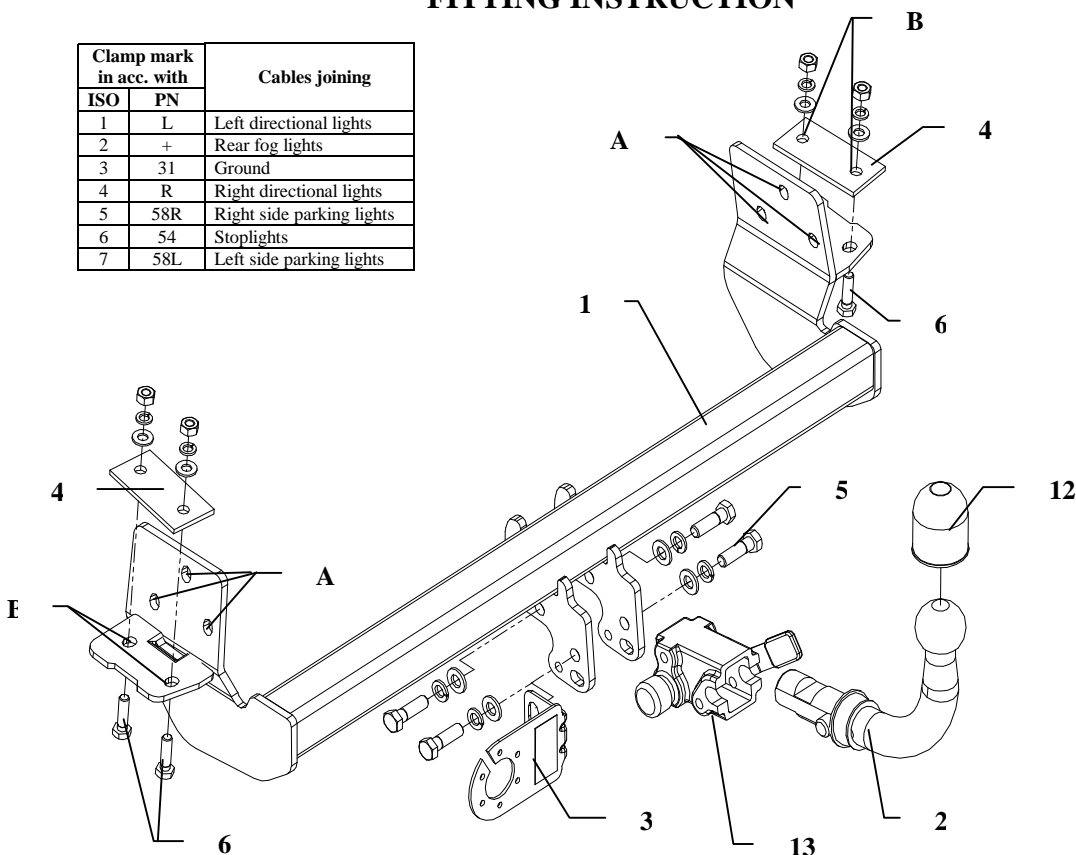

This towbar is designed to assembly in following cars:
TOYOTA COROLLA KOMBI E11 produced since 07.1997 till 07.2001, catalogue no. **O17A** and is prepared to tow trailers max total weight **1400 kg** and max vertical load **75 kg**.

From manufacturer

Thank you for buying our product. Their reliability has been confirmed in many tests. Reliability of towbar depends also on correct assembly and correct exploitation. For this reasons we kindly ask to read carefully this instruction and apply to hints.

The towbar should be install in points described by a car producer.

Assemble instruction

1. Disassemble the bumper.
2. Disassemble original transport handles (not used any more)
3. Put main bar of the towbar (pos. 1) and fix it through holes pos. A using bolts from original handles.
4. Through holes pos. B and fish-plate pos. 4 fix by bolts M10x35mm (pos. 6).
5. Reassemble the bumper after cut out his small fragments. See supplied template.
6. Fix body of the automat (pos. 13) and the socket plate (pos. 3) using bolts M12x25mm (pos. 5) from accessories. Place tow-ball (pos. 2) according to supplied instruction.
7. Tighten all bolts according to the torque shown in the table.
8. Connect electric wires of 7-poles socket according to the instruction of the car. (Recommend to make at authorized service station)
9. Complete paint layer damaged during installation.

Torque settings for nuts and bolts (8,8):

M 8	25 Nm	M 10	55 Nm
M 12	85 Nm	M 14	135 N







NOTE

After install the towbar you should get adequate note in registration book (at authorised service station).The car should be equipped with:

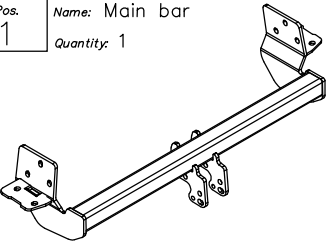
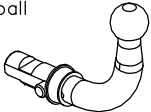
- Indicators
- Tow mirrors

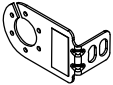
After 1000km check all bolts and nuts. The ball of towbar must be always kept clear and conserve with a grease.

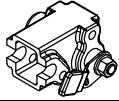
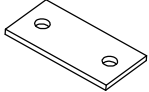
Towbar accessories:

Pos. 1 Name: Main bar Quantity: 1	Pos. 5 Name: Bolt 8,8 B Quantity: 4 Dim.: M12x25 mm	Pos. 10 Name: Spring washer Quantity: 4 Dim.: \varnothing 12,2 mm
	Pos. 6 Name: Bolt 8,8 B Quantity: 4 Dim.: M10x35 mm	Pos. 11 Name: Spring washer Quantity: 4 Dim.: \varnothing 10,2 mm
Pos. 2 Name: Tow ball Quantity: 1	Pos. 7 Name: Nut 8 B Quantity: 4 Dim.: M10	Pos. 12 Name: Ball cover Quantity: 1
		
Pos. 3 Name: Socket plate Quantity: 1	Pos. 8 Name: Plain washer Quantity: 4 Dim.: \varnothing 13 mm	Pos. 13 Name: Body of automaton Quantity: 1
		
Pos. 4 Name: Fisch-plate Quantity: 2	Pos. 9 Name: Plain washer Quantity: 4 Dim.: \varnothing 10,5 mm	Pos. 14 Name: Plug body Quantity: 1
		



PPUH AUTO-HAK S.J.

Produkcja Haków Holowniczych
Henryk & Zbigniew Nejman
76-200 SŁUPSK ul. Słoneczna 16K
tel/fax (059) 8-414-414; 8-414-413
E-mail: office@autohak.com.pl
www. autohak.com.pl

Towing hitch (without electrical set)

Class: **A50-X** Cat. no. **O17A**

Designed for:

Manufacturer: **TOYOTA**

Model: **COROLLA**

Type: **ESTATE E11**

produced since 07.1997 till 07.2001

Technical data:

D-value: 7,72kN

maximum trailer weight: **1400 kg**

maximum vertical cup load: **75 kg**

Approval number acc. to regulations EKG/ONZ 55.01: E20-55R-01 1740

Foreword

This towbar is designed according to rules of safety traffic regulations. The towing hitch is a safety component and can be install only by qualified personnel. Any alteration or conversion of the towing hitch is prohibited and would lead to cancellation of design certification. Remove insulating compound and underseal from vehicle (if present) in the area of the matting surfaces of the towing hitch.

The vehicle manufacturer's specifications regarding trailer load and max. vertical cup load are decisive for driving, and values for the towing hitch cannot be exceeded.

D-value formula:

$$\frac{\text{Max trailer weight [kg]} \times \text{Max vehicle weight [kg]}}{\text{Max trailer weight [kg]} + \text{Max vehicle weight [kg]}} \times \frac{9,81}{1000} = D \text{ [kN]}$$